

DC/AC CURRENT PROBE

CM-05

USERS MANUAL

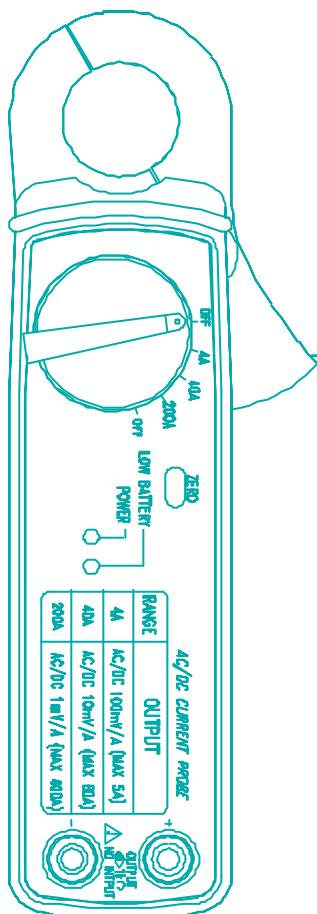

PROVA INSTRUMENTS INC.



EN 61010-2-032
CAT II 600V
CAT III 300V
Pollution Degree 2

Definition of Symbols:



Caution: Refer to Accompanying Documents



Caution: Risk of Electric Shock



Double Insulation

Overvoltage Category I (CAT I):

Equipment for connection to circuits in which measures are taken to limit the transient overvoltages to an appropriate low level.

Overvoltage Category II (CAT II):

Energy-consuming equipment to be supplied from the fixed installation.

Overvoltage Category III (CAT III):

Equipment in fixed installations.

WARNING: If the clamp meter is used in a manner Not specified by the manufacturer, the protection Provided by the clamp meter may be impaired.

TABLE OF CONTENTS

I.Features.....	1
II. Panel Description.....	2
III.Operation Instructions	3
A. DC Current Measurement	3
B. AC Current Measurement	3
C. Current Waveform Observation (Connected to an Oscilloscope).....	4
IV.Specifications	4
V.Battery Replacement	6
VI. Maintenance & Cleaning.....	6

I.Features

1. Accurate DC/AC current probe for current measurement.
2. 10mADC, 1mAAC high resolution.
3. One touch zero for DCA adjustment.
4. 23 mm diameter jaw.
5. Easy single rotary switch for any function selection.

II. Panel Description

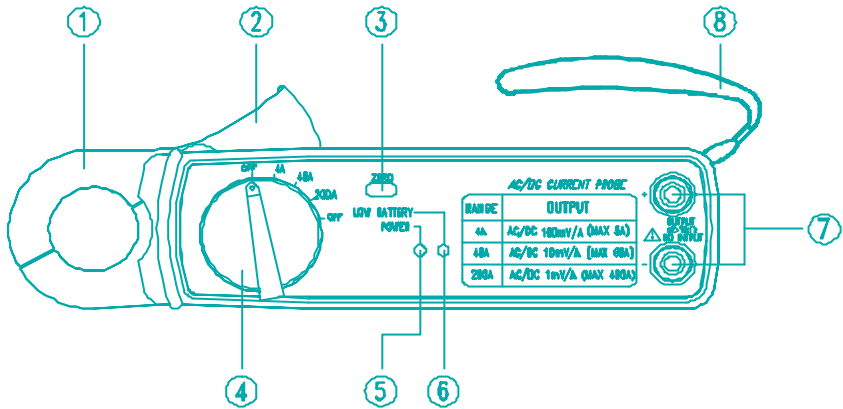

- 1. Transformer Jaw**
To measure DC/AC current, enclose the conductor by the jaw.
- 2. Transformer Trigger**
Push the trigger to open the jaw.
- 3. Zero Button**
Push the zero button to zero the output voltage before measuring any current.
- 4. On/Off and Range Selection Switch**
Turn the rotary switch to select the desired range.
- 5. Power-on LED**
When the unit is turned on, this LED will be lighted.
- 6. Low Battery LED**
When the battery voltage is lower than the required voltage, this LED will be lighted while the power-on LED will be off.
- 7. Output Terminals**
The output voltage is proportional to the current measured. Black terminal is the signal ground while red terminal is the signal. Do not input any live voltage to these terminals.
- 8. Hand Strap**
Put your hand through the hole of the hand strap to avoid accidental drop of the clamp meter.

III. Operating Instructions

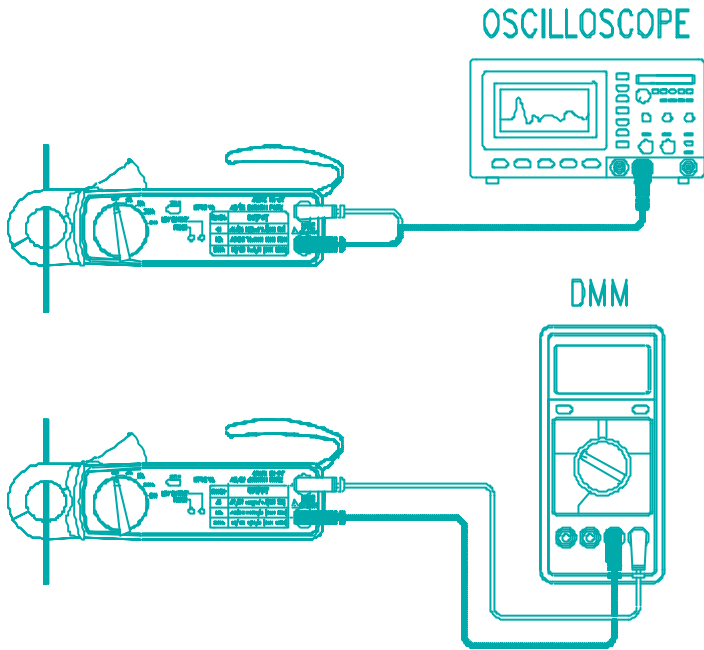

A. DC Current Measurement

1. Set the rotary switch at 4A, 40A or 200A.
2. Plug one end of each test lead into the meter terminals
3. Plug in the other end of the test lead into a multimeter.

4. Make sure current probe's and multimeter's COM terminals are connected.

5. Set the range of multimeter at **200 or 400 mVDC for DC current measurement.**
6. Push the zero button to adjust the reading of multimeter to zero.
7. Press the trigger to open the jaw and fully enclose the conductor to be measured. No air gap is allowed between the two half jaws.
8. Read the measured value from the meter's display.

B. AC Current Measurement

1. Set the rotary switch at 4A, 40A or 200A.

- 2.Plug one end of each test lead into the meter terminals
- 3.Plug in the other end of the test lead into a multimeter. It is strongly recommended a **TRUE RMS multimeter is used for AC current measurement for more accurate reading.**
- 4.Make sure current probe's and multimeter's COM terminals are connected.
- 5.Set the range of multimeter at **200 or 400 mVAC for AC current measurement.**
- 6.Press the trigger to open the jaw and fully enclose the conductor to be measured. No air gap is allowed between the two half jaws.
7. Read the measured value from the meter's display.

C. Current Waveform Observation (Connected to an Oscilloscope)

1. Find a BNC converter which converts the test plugs into BNC connector.
2. Set the rotary switch at 4A, 40A or 200A.
3. Connect the test plugs into current probe's terminals.
4. Connect the other ends of test leads into BNC converter.
5. Connect the BNC converter into oscilloscope's input.
6. Make sure the polarities of current probe and oscilloscope are connected correctly.
- 7.Press the trigger to open the jaw and fully enclose the conductor to be measured. No air gap is allowed between the two half jaws.
8. Select appropriate voltage range(eg. mv/div) so that output (200mV or 400mV full scale) from current probe can be observed from oscilloscope.

IV.Specifications(23°C±5°C)

Range	Output	Accuracy
DCA 0-4A ¹	DC 100mV/A	±2.0%±0.005A
DCA 0-40A	DC 10mV/A	±1.0%±0.02A
DCA 0-150A	DC 1mV/A	±1.0%±0.2A
DCA 150-200A	DC 1mV/A	-2.2%±0.2A
ACA 0-4A	AC 100mV/A	±2.0%±0.005A(40-1KHz)
ACA 0-40A	AC 10mV/A	±1.5%±0.03A(40-1KHz)
ACA 0-150A	AC 1mV/A	±1.5%±0.3A(40-1KHz)
ACA 150-200A	AC 1mV/A	-2.2%±0.3A(40-1KHz)

¹In the 4ADC range, the output would show 0.4mV drifting (rdg, rdg+0.1, rdg+0.2, rdg+0.3, rdg+0.4, rdg+03, rdg+0.2, rdg+0.1, rdg,...).

Range	Sensitivity
DCA 0-4A ²	0.1mV/1mADC
DCA 0-40A	0.1mV/10mA DC
DCA 0-200A	0.1mV/100mA DC
ACA 0-4A	0.1mV/1mA AC
ACA 0-40A	0.1mV/10mA AC
ACA 0-200A	0.1mV/100mA AC

²In the 4ADC range, the output would show 0.4mV drifting (rdg, rdg+0.1, rdg+0.2, rdg+0.3, rdg+0.4, rdg+03, rdg+0.2, rdg+0.1, rdg,...).

Indoor Use

- Conductor Size: 23mm max. (approx.)
- Battery Type: two 1.5V SUM-3 AA
- Range Selection: manual
- Power Consumption: 6 mA (approx.)
- Low battery Indication: red LED lights
- Operating Temperature: -10°C to 50°C
- Operating Humidity: less than 85% relative
- Altitude: up to 2000M
- Storage Temperature: -20°C to 60°C
- Storage Humidity: less than 75% relative
- Dimension: 183mm(L)x61.3mm(W)x35.6mm (H)
7.2" (L) x 2.5" (W) x 1.4" (H)
- Weight: 190g (battery included)
- Accessories: Carrying bag x 1
Users manual x 1
Test leads
1.5V battery x 2

V. Battery Replacement

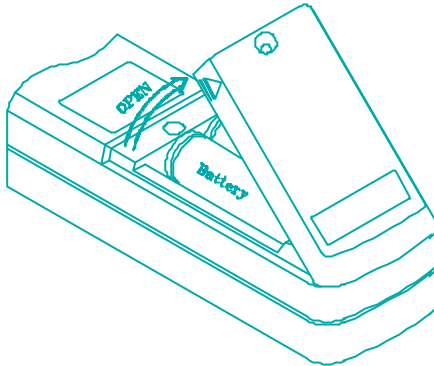

When the low battery LED lights, replace the old batteries with two new batteries.

- A. Remove the test leads from the current.
- B. Remove the screw of the battery compartment.
- C. Lift and remove the battery compartment.
- D. Remove the old batteries.
- E. Insert two new 1.5V SUM-3 batteries.
- F. Replace the battery compartment and secure the screw.

VI. Maintenance & Cleaning

Servicing not covered in this manual should only be performed by qualified personnel. Repairs should only be performed by qualified personnel. Periodically wipe the case with a damp cloth and detergent; do not use abrasives or solvents.

Address of Agent, Distributor, Importer, or Manufacturer

 <p>TVW-App</p>	<p>TVW Meßtechnik GmbH Semmelweg 31 32257 Bünde Fon: 05223 / 9277 - 0 Fax: 05223 / 9277 - 40 info@twwbuende.de www.twwbuende.de</p> 
--	---

